

# SmartPad: A Wireless, Adhesive-Electrode-Free, Autonomous ECG Acquisition System

Fred Chen, *Student Member, IEEE*, Henry Wu, Pei-Lan Hsu, Brad Stronger, Robert Sheridan, and Hongshen Ma

**Abstract**—During medical procedures, such as surgery, a patient's vital signs are typically monitored using a web of wires connected to adhesive electrodes. The large number of wires inhibits the medical team's access to the patient while the adhesive electrodes can detach, fail, or be out-of-stock, causing delays in the procedure. In order to combat these problems, we have developed the SmartPad: a system that displays a patient's electrocardiogram (ECG) signal without adhesive pads, wires, or active intervention from a clinician. The system automatically selects three electrodes from an array of Cu/Ni-fabric based electrodes patterned on a thin pad on which the patient lies. The selected electrodes are used to provide a differential 3-lead measurement of the patient's ECG, which is then transmitted wirelessly and displayed on a laptop computer.

## I. INTRODUCTION

In the ambulance, the operating room, and the intensive care unit, patient vital signs are obtained through various wires and adhesive electrodes attached to the patient [1]. The large number of wires inhibits the medical team's access to the patient, and in traumatized or burned patients, the adhesive pads will not stick to burns or bloody surfaces. Furthermore, in ambulances or other austere care sites, pads and leads must be stocked and resupplied.

Previous works addressing the need for unobtrusive ECG signal acquisition have primarily focused on low-cost mobile monitoring systems [2-5], and electrode technology for skinless contacts [6-8]. However, neither approach can be a low-cost replacement for current disposable electrodes and both require some level of human interaction to either place or determine the appropriate electrodes to use. Mobile monitoring systems still require precise placement of adhesive pads while skinless contact solutions require

relatively large electrodes that may not be suitable for certain patients such as children. Although an unobtrusive ECG measurement through clothing has been demonstrated [7], it requires active circuitry at the electrode end and does not address the problem of determining the proper electrodes to use.

To address these issues, we have developed the SmartPad system which automatically detects and selects the optimum electrodes to use from an array of electrodes patterned on a pad, and thus obviates the need for manual intervention. This electrode selection algorithm also allows the SmartPad system to select the electrode contacts as the patient shifts position or is transported. Combined with a low-cost electrode interface and wireless data transmission, the SmartPad system displays a patient's ECG signal without the need for adhesive pads, wires or any human intervention.

## II. SYSTEM DESCRIPTION

The SmartPad system schematic, shown in Fig. 1, is comprised of an array of electrodes connected to an analog multiplexing network followed by a three-lead ECG circuit consisting of amplifying, filtering, and sampling stages. The digitized data is transmitted to an application program running on a laptop. Communication between the ECG circuitry and the laptop can be either a ZigBee wireless link or a USB wired link.

Off-the-shelf hardware is used to implement various components of the system including an MSP430 microcontroller, an INA118 instrumentation amplifier, OPA340 op-amps, and SN74LVC2G66 analog switches (all from Texas Instruments). The RS232 transmission from the MSP430 is handled using either a FT232 chip (FTDI), which provides USB connectivity, or an XBee radio module (Maxstream), which provides ZigBee wireless connectivity.

Manuscript received April 6, 2008. This work was supported in by the Center for Integration of Medicine and Innovative Technology.

F. Chen is with the PhD Program in Electrical Engineering at the Massachusetts Institute of Technology, Cambridge, MA 02139 USA (e-mail: fredchen@mit.edu).

H. Wu is with the Master's Program in Electrical Engineering at the Massachusetts Institute of Technology, Cambridge, MA 02139 USA.

P. Hsu is with the Master's Program in Electrical Engineering at the Massachusetts Institute of Technology, Cambridge, MA 02139 USA.

B. Stronger is with the Department of Mechanical Engineering at the Massachusetts Institute of Technology, Cambridge, MA 02139 USA

R. Sheridan is with the Shriners' Hospital Children Boston and the Massachusetts General Hospital, both in Boston, MA 02114 USA

H. Ma is with the Department of Electrical Engineering at the Massachusetts Institute of Technology, Cambridge, MA 02139 USA (e-mail: hongma@mit.edu)

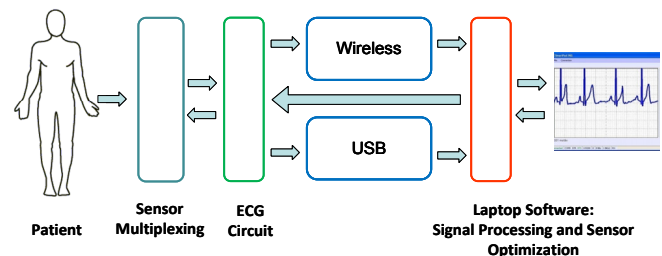

Fig 1. SmartPad system-level description

### III. MATERIALS AND METHODS

#### A. Fabric Electrode, Patterning, and Multiplexing

Since the SmartPad electrodes are in direct contact with a patient, the considerations used for choosing the electrode material include comfort, stain-resistance, and cost-effectiveness. A flexible conductive Ni/Cu polyester fabric tape from 3M (CN-3190) is used to create the electrode array. This material does not irritate bare skin and is resistant to corrosion. As shown in Fig. 2, this material is patterned onto a thin foam pad (or any similar substitute) and is connected to interface wires via its own conductive adhesive. The thin foam pad can then be placed in the target environment such as on a stretcher pad or operating table.

The electrode pattern, as shown in Fig 2, consists of a concentric series of ‘L’ shaped strips with a diagonal center strip. The electrode strips are one inch wide and are spaced approximately 0.5 inches apart. This geometry is designed so that the optimum ECG signal can be extracted by insuring that at least one combination of two electrodes form a vector across the patient’s heart, regardless of the size and orientation of the patient.

The multiplexing front-end chooses from one of four possible ‘L’ electrodes for both the  $In+$  and  $In-$  inputs. The three-lead ECG circuit used also requires an additional electrode contact to perform the common-mode cancellation. The pool of possible common-mode electrodes include the center diagonal electrode along with seven of the ‘L’ electrodes.

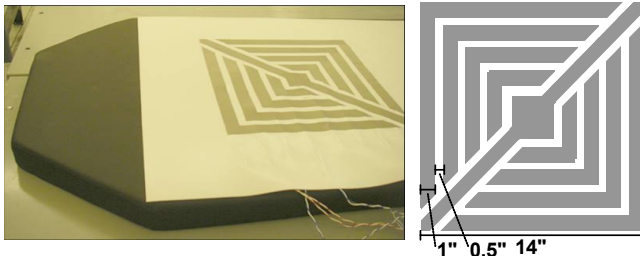

Fig 2. SmartPad electrode interface on top of a stretcher pad (left) and the electrode array pattern (right)

#### B. ECG Circuit

The ECG signal is obtained using a three-lead ECG circuit [9] instead of a two-lead circuit to improve immunity to the 60 Hz background and to reduce signal processing requirements. The three-lead ECG amplifier measures a differential signal across two input electrodes ( $In+$ ,  $In-$ ) and uses feedback via a third electrode (*Active GND*) to cancel the common-mode signal picked up by the input electrodes. This architecture allows the relatively weak ECG signal to be picked up above the stronger 60 Hz background.

Fig. 3 shows the schematic for the ECG amplifier. The inputs ( $In+$ ,  $In-$ , *Active GND*) to the amplifier come from the multiplexing network while the output is fed into the analog-to-digital converter (ADC) on the MSP430. The two input signals are buffered using an OPA340 op-amp. The

differential signal is amplified using an INA118 instrumentation amplifier, which provides a gain of 20 dB. A passive resistor and capacitor network serve to cascade a low-pass filter to a high-pass filter to eliminate high frequency noise and remove DC offset into the next gain stage. The final amplification stage uses another OPA340 op-amp to achieve an additional gain of 34-40 dB.

The ECG circuit operates entirely on a 3.3V power supply. The MSP430 microprocessor has an internal +2.5V reference used to reference the range of the ADC. The reference voltage in the ECG circuit,  $V_{REF}$ , is set at +1.25V, and is generated using a resistive divider and buffered using an op amp.

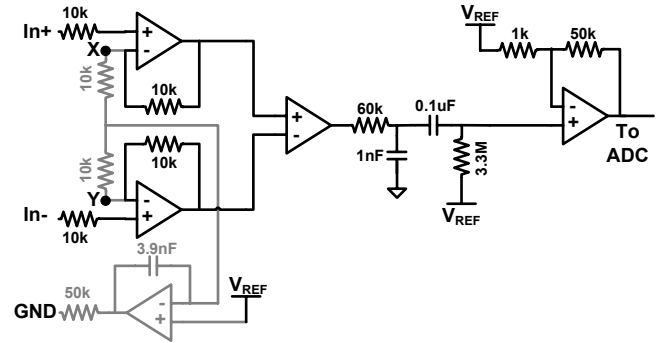

Fig 3. ECG amplifier and filtering circuits

In earlier prototypes, a 60 Hz notch filter was employed to remove power supply noise. However, experiments have shown that the three-lead ECG circuit is effective at removing the 60 Hz background when the circuit ground is isolated from the wall ground. Thus, the notch filter was deemed unnecessary and removed from later prototypes.

#### C. Signal Processing and Electrode Selection

The 10-bit multi-channel ADC on board the MSP430 is used to convert the amplified ECG signal at a 1.6 kHz sampling rate. Extension to higher resolution converters is straightforward and only requires the selection of a microcontroller with a higher resolution ADC.

In addition to the ECG signal, the signals at nodes X and Y in Fig. 3 are also digitized by the MSP430 to aid in the electrode selection process. The automatic electrode selection algorithm is performed in two steps. The first step determines whether or not the patient is in contact with the selected electrodes and the second step assesses the ‘quality’ of the acquired ECG signal.

Fig. 4 shows a time-lapse graph of the three digitized signals demonstrating a typical ECG acquisition sequence. During the first segment of time, the system is searching for a suitable set of electrodes to use. The system independently cycles through the pool of electrodes for each terminal starting from the inner electrodes. When the patient comes in contact with the selected electrodes, the system detects the patient, stops searching, and begins to acquire the ECG signal.

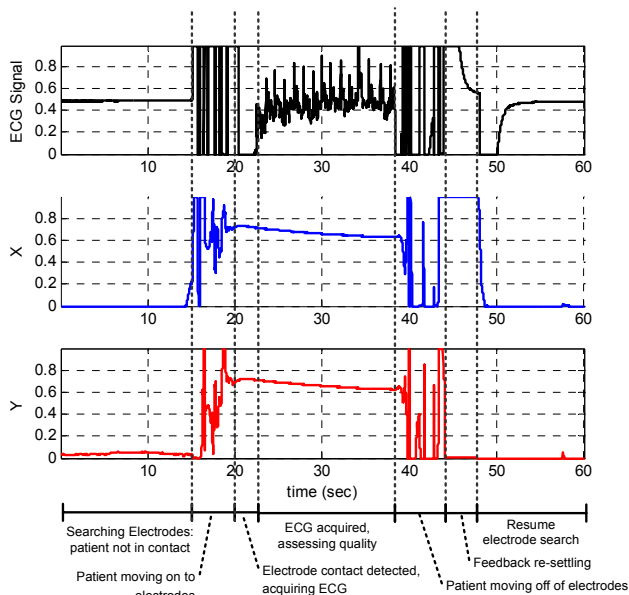

Fig. 4. Time lapse of the ADC outputs (normalized), for the ECG signal and input reference nodes X and Y. The time lapse shows an empty pad, a patient getting on the pad, and then getting off of it.

When the amplifier is functioning properly and the patient is making contact to the selected electrodes, the voltages at nodes X and Y should both be close to or greater than  $V_{REF}$ , which is the center of the ADC's input range. This can be seen in the middle time segment of Fig. 4. If, for example, the electrode selected for the  $In+$  input is not in contact with the patient, then the voltage at node X will be much lower than  $V_{REF}$ . If both input electrodes are not in contact with the patient then voltages at both X and Y will be below  $V_{REF}$ , as shown in the first and last time segments of Fig. 4. By observing the voltages at these two nodes, the system can quickly determine which electrodes in the array are in contact with the patient.

Once the system determines that the patient is making contact with the selected electrodes any number of existing heart-rate detection methods [10] can be used to determine the adequacy of the captured ECG signal. For our purposes, a simple histogram approach coupled with a differentiating heart rate detection scheme was sufficient. Typically, if the patient is in contact with the electrodes, an ECG signal is observed. However, if necessary, more complex algorithms can be implemented in real-time using additional hardware [4].

An important consideration for switching the electrodes and the corresponding high impedance connections to the circuit is to allow sufficient time for the high impedance circuitry to settle. From Fig. 4, we can see that once the patient is somewhat stable, the circuitry requires approximately two seconds to respond and settle. In order to limit the number of false negative triggers that might force the system to switch electrodes prematurely (even when there is sufficient contact with the patient), we limit the system to check the signal quality at most every four seconds.

#### D. Prototype Board and Display Application

Fig. 5 shows the prototype board used to implement the ECG and multiplexing circuitry. The PCB is roughly 4 inches by 4 inches but as evident from the figure, the area could be significantly reduced since much of the board space is occupied by the battery and empty space left for breakouts and debugging purposes. The application for displaying the digitized ECG data and communicating with the multiplexing hardware, also shown in Fig. 5, was developed using Visual Basic .NET and is compatible with any PC running Windows.

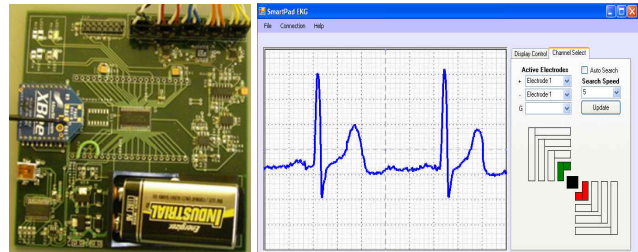

Fig. 5. SmartPad prototype circuit board and captured ECG and selected electrodes visualized on the PC display application

## IV. RESULTS

#### A. Power Consumption

Most of the power consumption for the system can be attributed to the XBee radio. The circuit consumes roughly 16.2mA when connected via ZigBee and only 350 $\mu$ A when using USB. In commercial development, lower-power and lower-range radio transmitters can be used to reduce overall power consumption and extend battery life.

#### B. Body Position and Orientation Dependencies

To assess the performance of our system, we tested the system on the members of the design team over various scenarios. The intended functionality of the prototype was to demonstrate unassisted automatic detection and acquisition of an ECG signal of a single vector across the heart and not to replicate full functionality of standard 3-lead, 6-lead and 12-lead ECG systems. Thus, the primary indicator for success was whether or not the system could automatically acquire a good ECG signal as the subject changed positions and orientations on the pad.

Fig.6 shows ECG signals captured while the subject is lying on his right side, back, left side and chest. As expected, the plots indicate that body position affects both signal amplitude as well as polarity. This is particularly evident in the ECG taken off of the chest. Results when the patient is not vertically aligned with the pad show similar results and despite the differences, in each case, the signal quality acquired is sufficient and demonstrates that the system is able to select the appropriate electrodes and extract the patient's ECG regardless of body position or orientation.

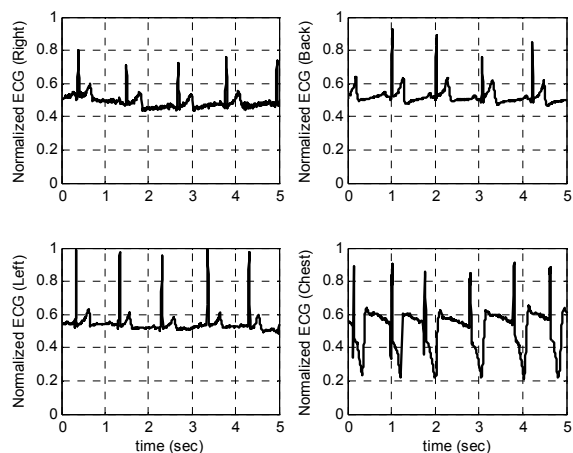

Fig. 6. Captured normalized ECG signals for different patient body positions: lying on the right side, back, left side and chest.

### C. Noise Performance

As discussed previously, the circuit topology and battery powered operation removed the need for a 60 Hz notch filter. To demonstrate the immunity of the design to 60 Hz noise, Fig. 7 shows ECG signals captured while the patient is on his right side and on his back for both the battery-powered and wall-powered cases. As the plots indicate, there is little noise in either of the battery-powered results while the wall-powered result captured from the patient's right side shows a noticeable increase in 60 Hz noise. The difference between the right side and back results for the wall-powered case is likely due to the body coverage of the electrodes, as the electrodes are partially exposed for the prior case, allowing easier pick up of 60 Hz line noise.

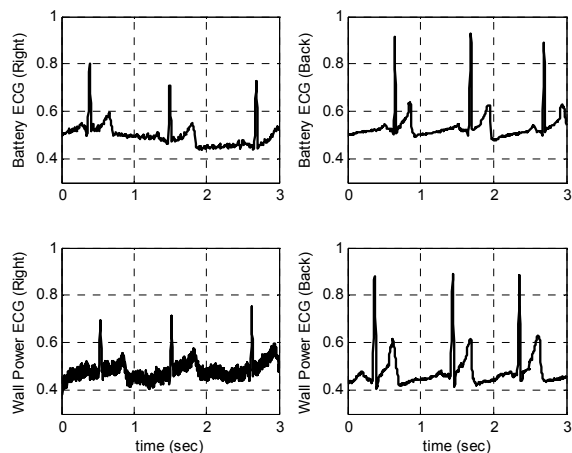

Fig. 7. Captured normalized ECG while patient is lying on his right side (left 2 figures) and back (right 2 figures) when circuit is battery-powered (top 2 figures) and powered from a wall-powered supply.

## V. CONCLUSION

We have developed and demonstrated a low-cost solution to providing unobtrusive and autonomous ECG monitoring for patients requiring medical attention. Our electrode configuration and detection algorithm enables “hands-free” operation on the part of the clinician and shows the noise benefits of using a wireless acquisition system. This device

requires no conscious attention from the medical staff and therefore enables them to more efficiently treat patients.

Although the demonstrated system targets a specific set of applications, many of the components described here translate to other applications as well. For example, while the current SmartPad uses electrodes making an ohmic contact to the skin, the methodologies employed for automatic electrode detection are compatible with existing non-contact techniques [6-8]. Furthermore, the “hands-free” aspect of the system would be just as appealing in a home monitoring setting as in a medical environment.

Further improvements to the system include enabling standard 3-lead/6-lead ECG functionality, acquiring other vital signs and improving the usability and robustness of the system. Redundant hardware could be added to achieve standard ECG functionality by enabling simultaneous capture of multiple vectors across the heart. The robustness of the system could be improved by using additional hardware and/or more complex detection algorithms to assess the signal ‘quality’. Meanwhile, additional vital sign monitors, such as pulseoximetry and breath rate sensors, might be also be integrated into the bottom pad.

## ACKNOWLEDGMENT

The authors would like to acknowledge Shane Colton and Chris Salthouse for their help with debugging the prototype circuits.

## REFERENCES

- [1] Kearney, K, et al., “Quantification of Motion Artifact in ECG Electrode Design,” Engineering in Medicine and Biology Society, 2007. EMBS 2007. 29th Annual International Conference of the IEEE, pp.1533-1536, 22-26 Aug. 2007
- [2] C. Park and P.H. Chou, Y. Bai, R. Matthews, and A Hibbs. “An Ultra-Wearable, Wireless, Low Power ECG Monitoring System,” in Proc. IEEE BioCAS, Nov 29 - Dec 1, 2006.
- [3] [7] Linz, T., et al, “Fully Integrated EKG Shirt based on Embroidered Electrical Interconnections with Conductive Yarn and Miniaturized Flexible Electronics,” Proceeding of the International Workshop on Wearable and Implantable Body Sensor Networks, 2006.
- [4] S. Borromeo, et al. “A Reconfigurable, Wearable, Wireless ECG System,” Proceedings of the 29th Annual International Conference of the IEEE EMBS. Aug. 23-26, 2007.
- [5] F. Axisa, A. Dittmar, and G. Delhomme. “Smart Clothes for the Monitoring in Real Time and Conditions of Physiological, Emotional, and Sensorial Reactions of Human,” Proceedings of the 25th Annual International Conference of the IEEE EMBS. Sept. 17-21, 2003.
- [6] A. Ueno, et al. “Capacitive Sensing of Electrocardiographic Potential Through Cloth From the Dorsal Surface of the Body in a Supine Position: A Preliminary Study,” IEEE Transactions on Biomedical Engineering, Vol. 54, No. 4. April 2007
- [7] Y.G. Lim, K.K. Kim, and K.S. Park. “ECG Recording on a Bed During Sleep Without Direct Skin-Contact,” IEEE Transactions on Biomedical Engineering, Vol. 54, No. 4. April 2007.
- [8] M. Ishijima. “Monitoring of Electrocardiograms in Bed Without Utilizing Body Surface Electrodes,” IEEE Transactions on Biomedical Engineering, Vol. 40, No. 6. June 1993.
- [9] Oberg, T; “A Circuit for Contact Monitoring in Electrocardiography”, IEEE Transactions on Biomedical Engineering, Volume BME-29, May 1982 Page(s):361 - 364
- [10] Kohler, B.-U.; Hennig, C.; Orglmeister, R. “The principles of software QRS detection”, Engineering in Medicine and Biology Magazine, IEEE Volume 21, Issue 1, Jan.-Feb. 2002 Page(s):42 - 57