

Pulse Oximetry

Dave Hoff
Roy Zhang
Tad Stalter
Mike Carlson

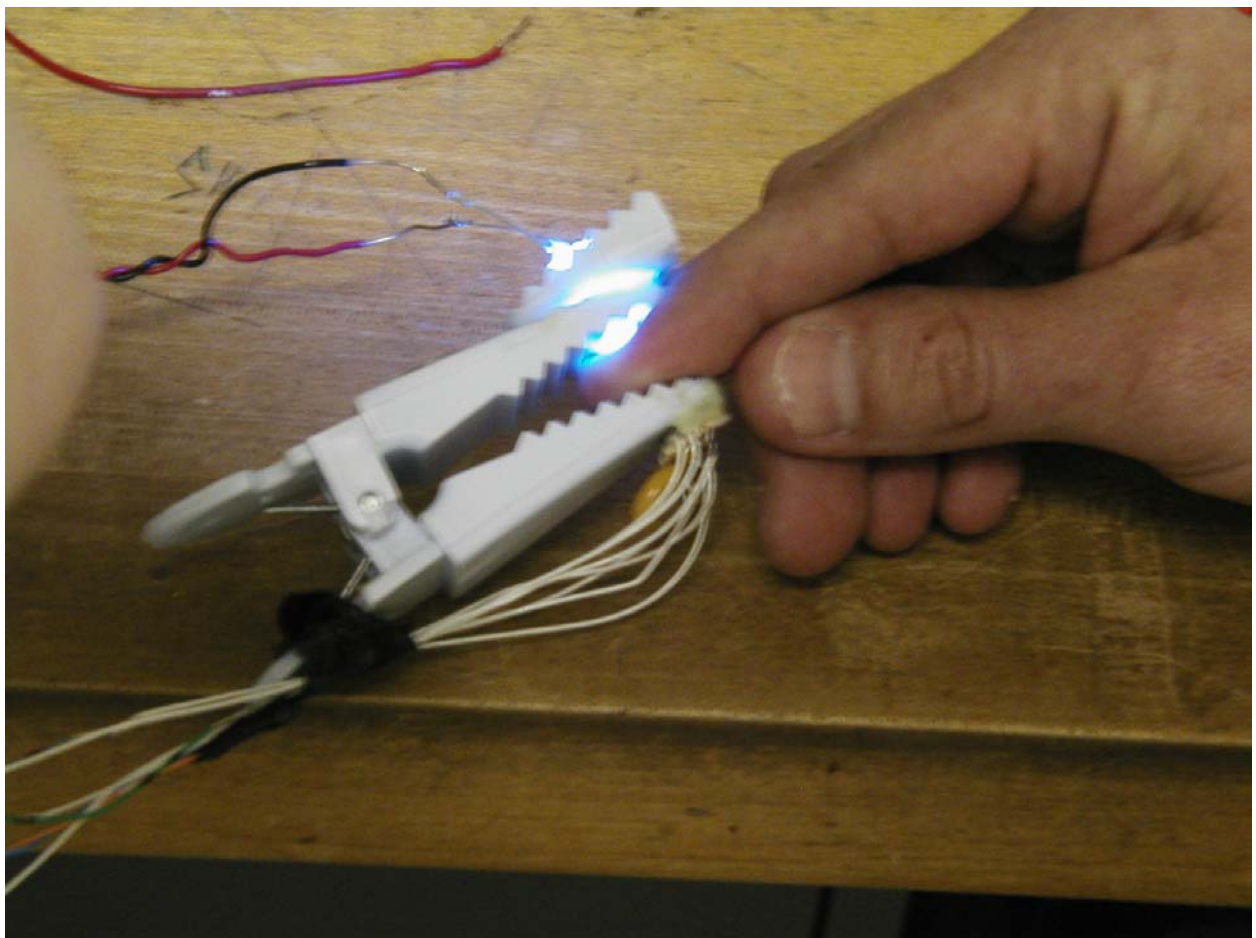

INTRODUCTION TO PULSE OXIMETRY

The oxygenation and deoxygenation of blood is a process rarely considered, but occurs with every breath. When someone breaths air in from the atmosphere, about 20% of what they breathe is oxygen. The oxygen rich air travels down to the lungs where it is exchanged across a membrane into oxygen depleted hemoglobin. The oxygenated hemoglobin then flows through the arterial system to the heart where it is distributed throughout the body to the tissues. In the tissues the oxygen is used up, and the

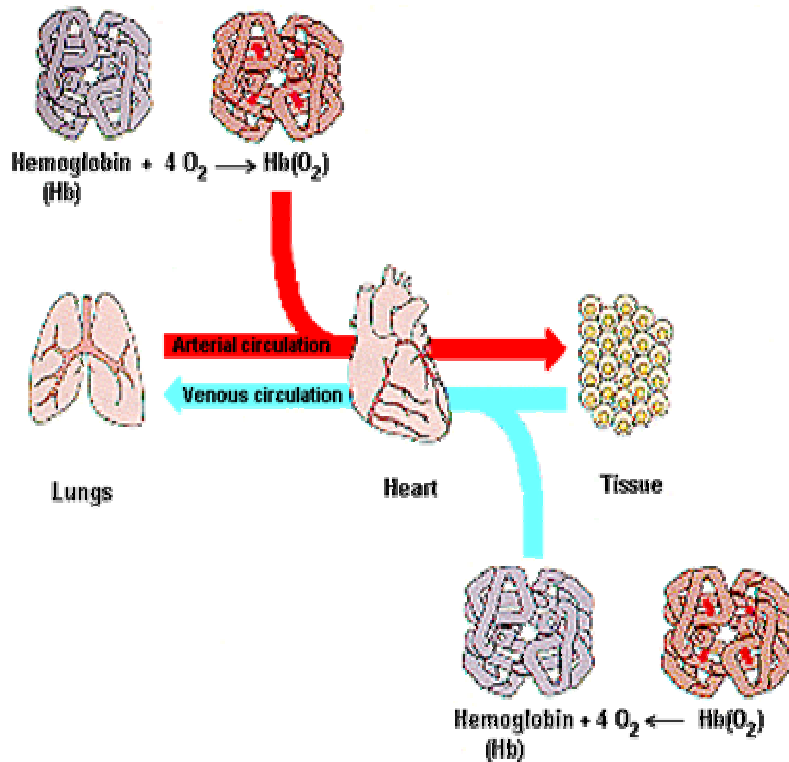

byproduct, or waste, carbon dioxide, is then carried back through the venous system, through the heart, then back to the lungs where the carbon dioxide can be expelled from the body by exhaling. This process occurs with every breath someone takes and is illustrated in **Figure 1** [1].

Figure 1. Oxygenation and deoxygenation of blood in the body. [1]

When someone lacks sufficient oxygen in their blood supply they are said to have hypoxia. There are varying degrees of hypoxia based on how low the oxygen levels in the blood are. The symptoms are not easily

detected, especially in cases of acute hypoxia. The more subtle effects of hypoxia are poor judgment and loss of motor function. Hypoxia can, however, be deadly since, by definition, not enough oxygen is being transported from the bloodstream to the tissues of the body. The most sensitive tissue to hypoxia in the body is the brain. The condition that occurs when the brain does not receive enough oxygen is called cerebral hypoxia. Five minutes is all it takes for a brain cell to die in the absence of oxygen. If the hypoxia lasts for prolonged periods it can lead to “coma, seizures, and even brain death. In brain death, basic life functions such as breathing, blood pressure, and cardiac function are preserved, but there is no consciousness or response to the world around.” [2]

The four main variations of hypoxia include stagnant hypoxia, hypemic hypoxia, histotoxic hypoxia, and hypoxic hypoxia. Stagnant hypoxia occurs when the blood flow is restricted to an area of the body cutting off the oxygen supply. An example of this is when someone is cramped for a while and their foot falls asleep. Hypemic hypoxia occurs when the functional hemoglobin count is low, thus not having enough hemoglobin

to transport the oxygen throughout the body. Histotoxic hypoxia occurs when tissue cells become poisoned and can't properly use the oxygen. This might occur due to carbon monoxide poisoning. Hypoxic hypoxia occurs due to lack of oxygen available to breathe in. This occurs at high altitudes and is of major concern to pilots. [3, 4]

There are physiological causes for hypoxia, one of which is due to complications during anesthesia. During anesthesia there can be many factors that can occur to induce the onset of hypoxia. They include: low cardiac output, pulmonary edema, pulmonary embolism, airway obstruction, and endobronchial intubation among others [5].

There are many times when it would be useful to be able to monitor the blood oxygen levels in a person to catch and treat hypoxia before its effects can harm the individual. These situations include: in the operating room during anesthesia in case something unexpected goes wrong, in the post operating room where the patient will be recovering, in an ambulance while being transported to the hospital after a cardiac or pulmonary episode, and in the neonatal care unit to closely monitor a newborn's vital signs. By having a device to monitor the oxygenated hemoglobin levels, the physician is put at an advantage over any possible complications. It is for these reasons that pulse oximetry has become more prominent.

Pulse oximetry is a non-invasive and continuous method of determining the amount of oxygenated and deoxygenated hemoglobin in a person's blood supply. It is preferable to direct measurement of the oxygen levels in hemoglobin because it is able to be determined in real time while causing no discomfort to the patient. Traditional pulse oximeters take measurements from the finger and ear lobe. The first pulse oximeter was designed in the late 1930's by German researchers whose objective was to measure the oxygenation of "high altitude pilots." [6] From that point on, the pulse oximeter, as it was later called, has been improved upon continuously. In the last year alone there have been thousands of patents granted on ideas and devices concerned with pulse oximetry.

Pulse oximetry is accomplished by implementing the Beer-Lambert Law, which, in this case, relates the concentration of oxygen in the blood to the amount of light absorbed when transmitted through the blood. [7] The absorption of the light transmitted through the medium can be calculated using the Beer-Lambert Law as follows:

$$I_{OUT} = I_{IN} e^{-A} \quad (1)$$

Where I_{OUT} is the intensity of the light transmitted through the medium, I_{IN} is the intensity of the light going into the medium, and A is the absorption factor. [8]

There are different light absorption levels for oxygenated and deoxygenated hemoglobin at different wavelengths as can be seen in **Figure 2**. Traditionally, pulse oximeters make use of red ($\lambda=660\text{nm}$) and infrared light ($\lambda=940\text{nm}$) to determine the percentage of oxygenated hemoglobin present in the arterial system. These two wavelengths are chosen because, at 660 nm, deoxygenated hemoglobin has a higher absorption, whereas at 940 nm, oxygenated hemoglobin has a higher absorption. Once the absorption levels are detected, it is possible to determine the ratio of the absorption between the deoxygenated and oxygenated hemoglobin at the different wavelengths.

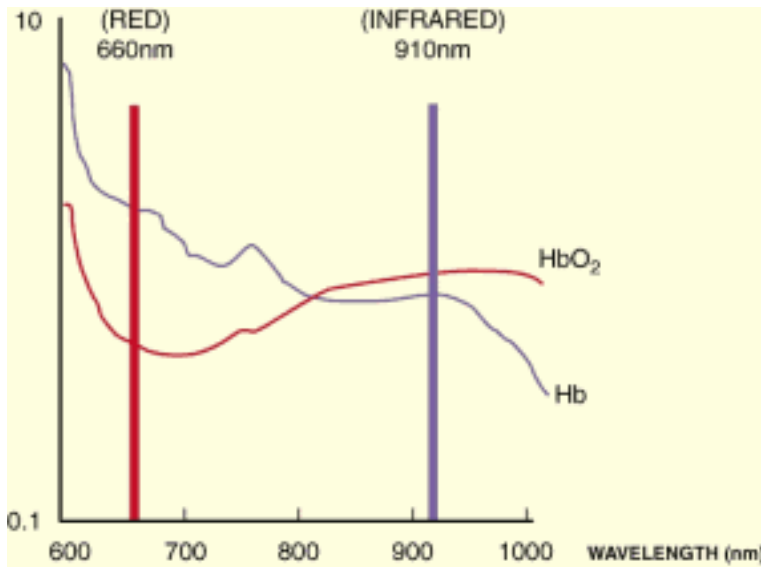

Figure 2. Absorption levels of oxygenated and deoxygenated blood at different wavelengths. [6]

The measurements taken by the pulse oximeter demonstrate the shape of a pulsatile waveform as seen in **Figure 3**. This pulsatile waveform has both AC and DC components in it. The DC components are comprised of the absorption from the non-pulsing arterial blood, the venous and capillary blood, as well as from scattering and absorption due to the tissue and bone. These components are always constant and rest on one

another as shown in the figure. The AC component of the figure 3 is the pulsatile waveform that we are interested in. This waveform represents the pulsing of the blood in

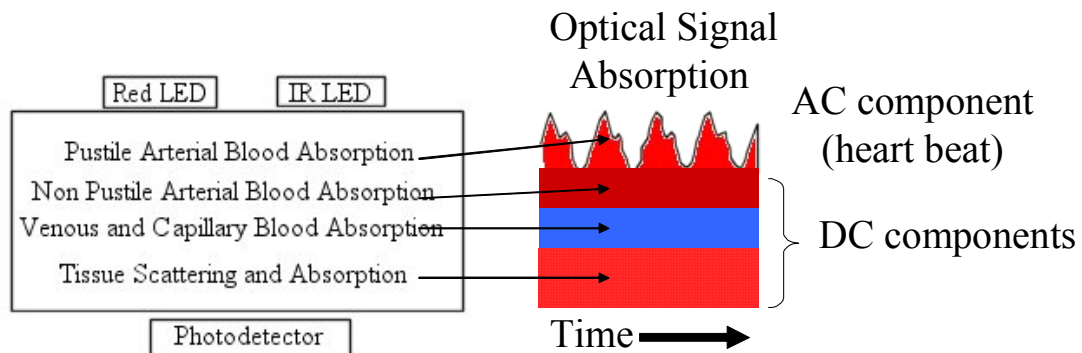

Figure 3. AC and DC components of oximetry. [Dr. Muth]

the arteries and each individual pulse can be seen, representative of the heart rate. This waveform is gathered for both light frequencies, in this case infrared and red light. In order to obtain the pulse oximeter saturation (SpO_2), these AC and DC components from each of the wavelengths need to be measured and taken as a ratio as follows: [8]

$$R = [AC_{\lambda_1} / DC_{\lambda_1}] / [AC_{\lambda_2} / DC_{\lambda_2}] \quad (2)$$

This ratio is then used in a calibration curve based on studies of healthy individuals to determine the SpO_2 . This value will end up being a percentage which will tell the physician whether or not everything is as it is supposed to be. A normal saturation level is between 87-97%. [9] This method of measuring the SpO_2 has been shown to be accurate to within 2.5%. [7]

BACKGROUND AND DESIGN CONSIDERATION

Oximetry is the determination of the amount of oxygen that is saturated in blood. Its history dates back to the early 1860, when a professor of applied chemistry Felix Hoppe-Seyler coined the term hemoglobin to describe the blood that absorbs green and blue light. [12]

Traditional pulse oximetry is done using a red LED and a infrared LED. The light is partly absorbed by hemoglobin, which differ depending on whether the hemoglobin is saturated or unsaturated with oxygen. The light then passes through the finger and into a photo detector (**Figure 4**). By calculating the absorptions at the different wavelengths, the amount of hemoglobin, which is oxygenated, can be computed. This method of pulse oximetry has been practiced using extremities of the body such as fingers, toes, and ear lobes. For neonatal purposes the pulse oximeter is used on the palm of the hand or the foot. [11]

Pulse Oximetry - Theory

From: IEEE Biomedical Engineering Handbook pgs 1349-1352

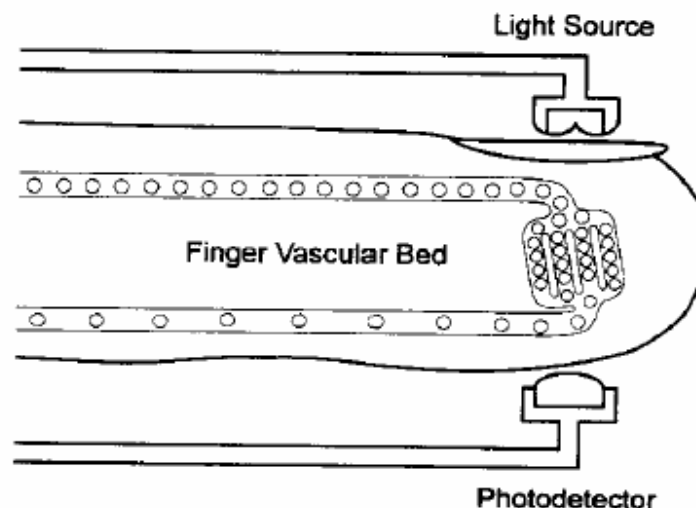

Figure 4.

Pulse oximeters need to be calibrated during manufacturing, and need to automatically check their internal circuits when they are turned on.

Our design team decided to try to eliminate the need for using two LED's to get two different wavelengths of light. This would allow less calibration of the device. To do this we tried using a blue LED and a ruby. Passing the light through the ruby produces blue light and red light. The problem with using blue light is that it is absorbed at much higher rates in the body than infrared light. We had to come up with many different methods to overcome this problem.

A New Idea for Pulse Oximetry

As mentioned in the first part of this report, the traditional pulse oximeter uses two Red and Infrared LEDs shining alternatively as its light source. It has to include some circuits to switching between these two LEDs and stabilize the ratio of Red to Infrared intensities so that the pulse oximeter could make accurate and stable measurements. Our new idea is that, to simplify the circuitry for switching and calibration, replace the two LEDs by a Blue LED with a Ruby. Since the energetic photon from Blue LED can optically excite red emission from Cr:Sapphire (Ruby), the Red to Blue ratio is always fixed and there's no need for calibration. Besides, it is also possible to grow InGaN (Indium Gallium Nitride) Blue LED on the Ruby substrate and integrate them into one new device for pulse oximeter.

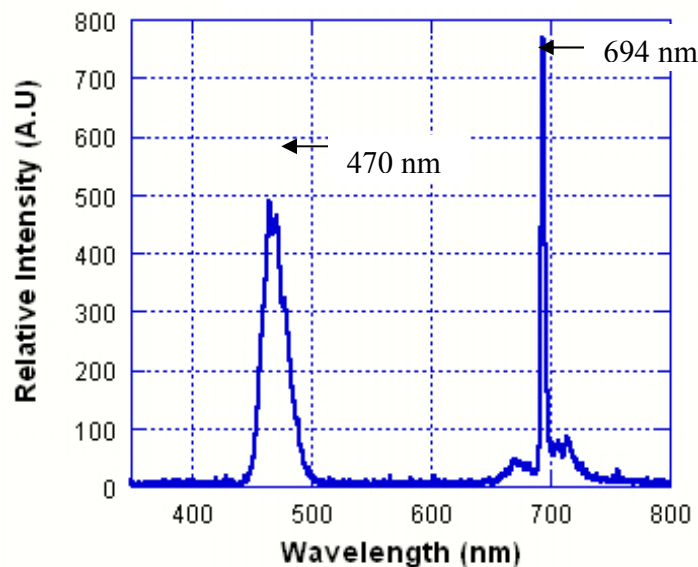

Figure 5 Spectrum of Commercial Blue LED with Ruby [13]

The emission spectrum from a Ruby excited by a commercial Blue LED (1000 mcd intensity from DigiKey) is shown in **Figure 5**. The 694 nm red emission from Ruby has a very narrow bandwidth that could be a good optical source for spectroscopy. **Figure 6** demonstrates the mechanism of Blue LED exciting Ruby. Blue photon excites the electrons in Chromium Ions of Ruby from ground state to 4F bands, then rapid nonradiative decay happens and electrons transits back to a metastable doublet. The 694 nm red light comes from doublet emission between Chromium atomic energy levels and that's why it has such a narrow bandwidth.

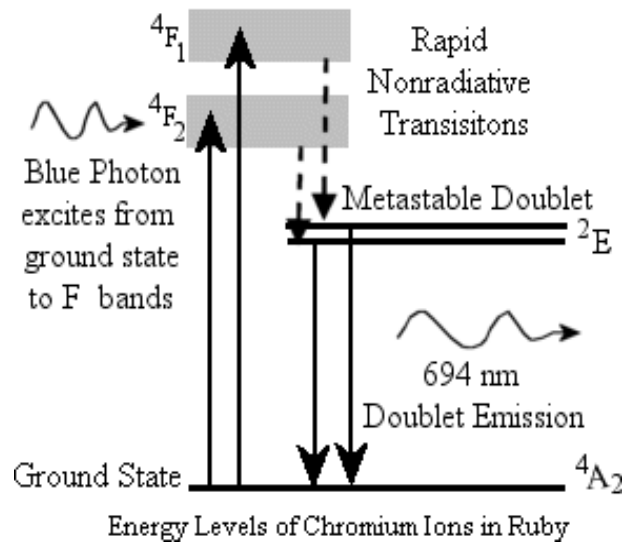

Figure 6 Physics of Red emissions from Ruby excited by Blue photons

Another motivation for redesigning the pulse oximeter is that the research group directed by Dr. John Muth in North Carolina State University is growing InGaN Blue LEDs on the Ruby substrates. **Figure 7(a)** shows the structure of such a device and its electroluminescence has also been measured [**Fig 7(b)**]. Although the spectrum is not as good as commercial LED with Ruby, the 470 nm and 694 nm peaks are still pretty clear. Improving the fabrication of integrated dual wavelength light emitter is another aspect of redesigning pulse oximeter. However, it is not in the scope of this project.

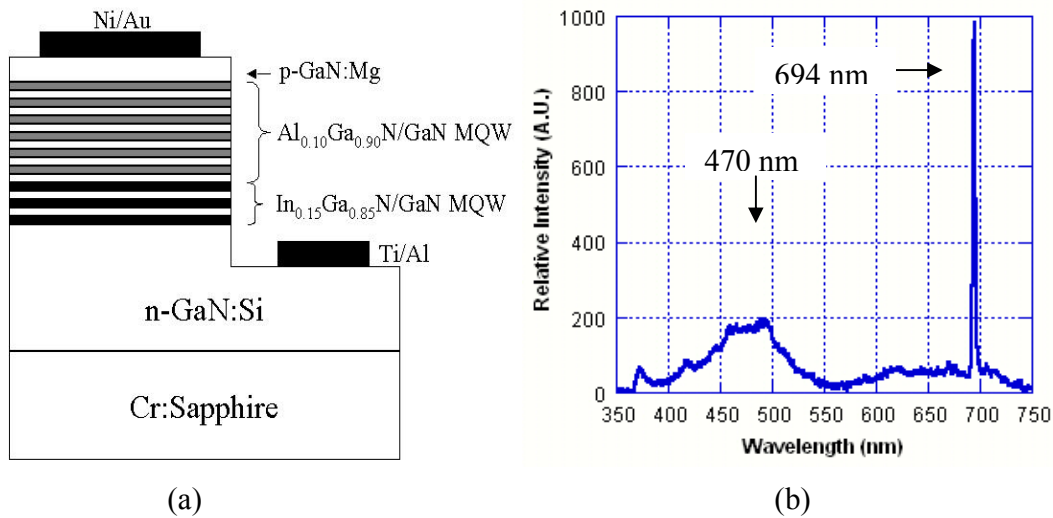

Figure 7 Integrated Optical Source of InGaN LED Grown on Cr:Sapphire (a) Device structure (b) Electroluminescence spectrum

Spectrometer Test

Before starting circuit design, some simple measurements on the spectra of our light source and transmission has been made first to get a rough idea about the optical system we were going to deal with. The optical setup is pretty straightforward – just using a lens to focus the emitted light from LED or transmitted light through finger to a photo detector. This is not a precise experiment, because we haven't calibrated either the light source or the photo detector. Since the distance between LED and detector is not fixed, even the relative intensity from different experiment is not comparable. However all of these are not what we concern. Because the absorption of blue light through finger is much stronger than that of the red, the *ratio* of blue and red transmission becomes the most important thing for us and therefore this simple experiment is already enough for giving us some information crucial to the circuit design.

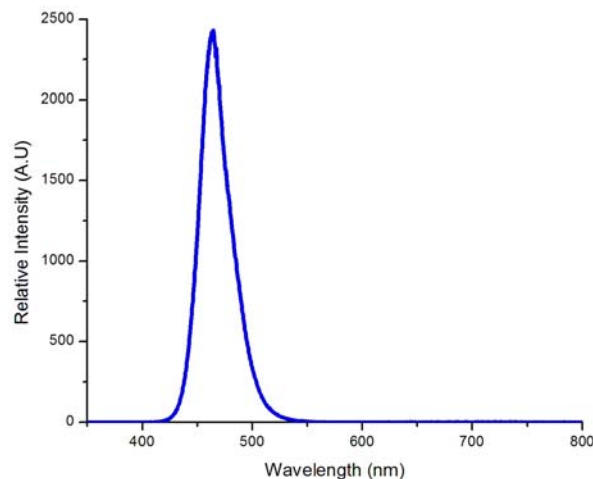

Figure 8 Emission Spectrum of Commercial Super Bright Blue LED

Ocean Optics USB2000 Miniature Fiber Optics Spectrometer [14] was used as the photo detector. It has an effective measurement range from 200 nm to 1100 nm and a resolution of 0.8 nm. **Figure 8 and 9** are emission spectra from a commercial super bright Blue LED alone and from such a LED with a Ruby ball, respectively. The reason why **Figure 9** is different from the result shown in **Figure 5** is that a super bright LED (5500 mcd from Red Line, Inc) was used as light source to produce more transmission and thus increased the Blue to Red ratio.

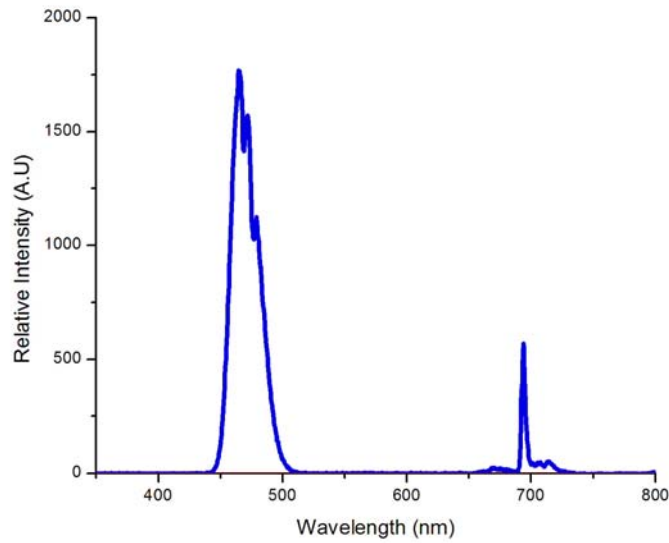

Figure 9 Spectrum from super Blue LED and Ruby

The transmission result is shown in **Figure 10**, inserted graph is the spectral detail from 440 nm to 510 nm (Blue). Transmitted blue light is much weaker than the red even incident blue is stronger than red. The integral time for acquiring this spectrum has been increased dramatically to 5000 milliseconds. However, since the spectrometer actually acquires a whole spectrum in five second, with a 0.8 nm resolution this means measuring more than one thousand points. So the signal might be still detectable for a single photodiode if can be detected by such a spectrometer. Although the blue transmission is very weak, the follow parts of this report will discuss how to detect it with using a sensitive enough photodiode and designing the right circuit.

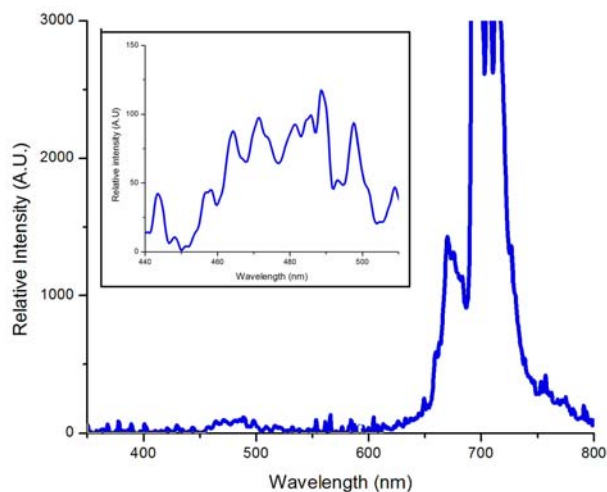

Figure 10 Transmission Result with Blue LED plus Ruby

Reflectance Trials

Our first attempt was to use reflectance rather than transmission of the light to measure the absorption of the different lights. We used a beam splitting cube, which can be used to redirect the reflected light from the skin. There is an additional advantage of this technique in that the readings can be taken any where on the body.

In the **Figure 11** below, the beam splitter splits the light where 50% of the light is reflected out of the cube and the rest is passed to the skin. The reflected light from the skin is also reflected by 50% out of the cube where a light sensor was placed.

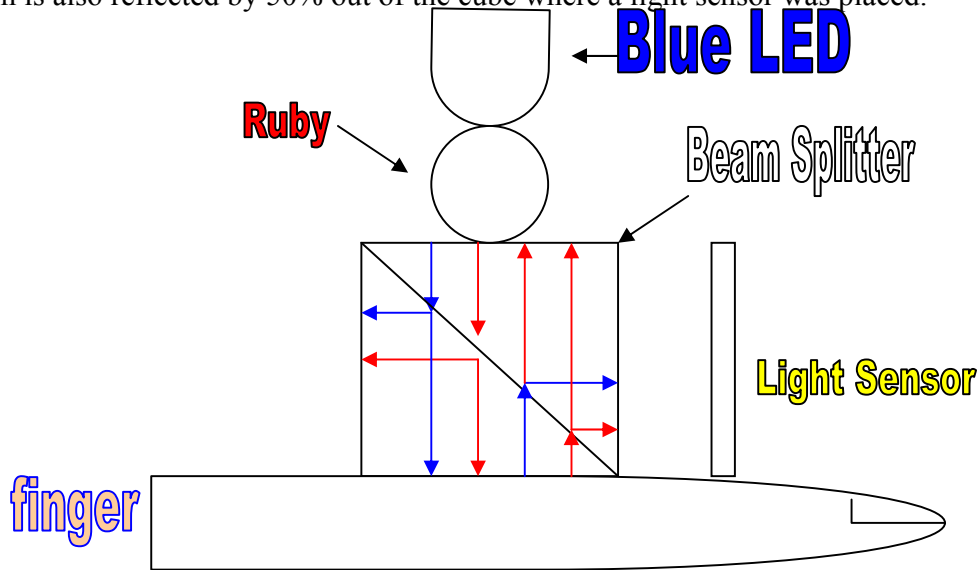

Figure 11. Diagram for reflectance oximetry using a beam splitting cube.

The problem with this method is that too much blue light was reflected out of the beam splitting cube. This did not allow enough light to reach the skin to be reflected back to the light sensor.

In our next attempt, we tried to get rid of the beam splitting cube and just use reflectance from the skin (**Figure 12**). Special care was taken to make sure that light from the LED did not bleed over to the sensor before reflecting off the skin.

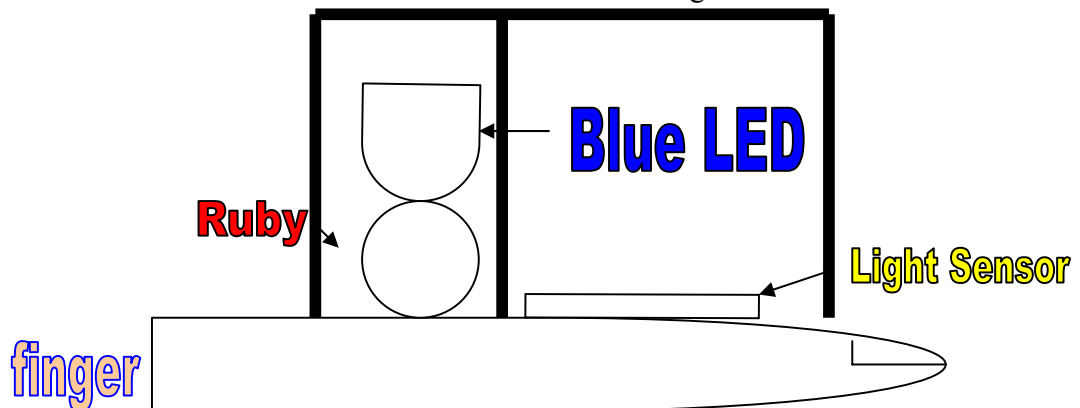

Figure 12. Diagram for reflectance oximetry.

The problem with this method that light reflected off the surface of the skin instead of getting further down past the tissue to get a pulse waveform. Also, there was a problem with light leaking through to the light sensor from the blue LED and ruby.

Design Considerations

To implement the Pulse Oximeter circuitry, six main function blocks were designed in hardware: 1) LED driver, 2) Light Sensor, 3) Frequency to Voltage Conversion, 4) Amplification, 5) Switching Glitch Suppression, 6) Switching Control (see system block diagram Figure 13, page 14). The following discussion details each block and its design. All designators reference the schematic (see Appendix pg. 22)

LED Driver

Because blue light is absorbed an order of magnitude more than red light, a very bright LED was needed. Researching available blue LEDs on the market resulted in our choosing a 5500mcd RL5-B5515 blue LED from superbright LEDs [15]. To achieve maximum light intensity without producing unwanted light frequencies by overdriving the LED, the maximum rated current of 25mA was achieved using a 75 Ω resistor (R33). The long leads from the board level supply to the finger probe were twisted to prevent 60Hz noise from modulating the light intensity.

Light Sensor

Because both red and blue light are transmitting through the patient simultaneously, a switchable sensor that selects sensitivity to the two colors was necessary. Further, because the transmitted intensity of red and blue light was an order of magnitude different, a sensor with programmable sensitivity was also desired. TAOS has one such sensor, the TCS230 (I30). The TC230 provides a pulse train output with frequency being proportional to incident light intensity. The digital nature of this output further reduces the effects of 60Hz induced noise when sending the output over long leads from the probe to the main board.

To switch between red and blue sensitivity, input S2 is tied high and S3 is switched with the onboard 'pulse' signal. This selects either a bank of 16 on chip sensors with red filters or blues filters. The time needed for the output to stabilize after a switch is only 1 μ S, which is negligible compared to the frequency of the signals being measured.

Sensor sensitivity is also switched by tying input S0 to VDD and switching S1 with the 'pulse' signal. This allows for a 100% output range when measuring blue light and a 20% output range when measuring red light (maximum output for red intensity is 1/5 that of blue). This provides a smaller disparity in red vs. blue output amplitude for the subsequent frequency to voltage converter stage and ultimately the final analog output.

Frequency to Voltage Conversion

As stated previously, the output of the TCS230 light sensor is a pulse waveform with frequency proportional to measured light intensity. To better enable amplification and to provide a standard output for sampling systems, the pulse output was converted to an analog voltage using an LM2917 (I8). The design was modeled after the reference ‘Minimum Component Tachometer’ circuit in the datasheet [16] with a few modifications.

The reference circuit was designed for a sensor with a dual-rail output so the LM2917 reference input is tied to ground and as the input goes above and below ground, the internal comparator switches its output. The output of the TCS230 is 0-5V pulse. Therefore a 0.7V reference was provided to the internal comparator with diode D1, enabling internal switching on rising and falling TCS230 output pulses. R28 is provided for current limiting of D1.

The component in the reference circuit is a different version (LM2907) of frequency to voltage converter than the LM2917. A critical difference is that pin6 of the LM2917 is connected to a Zener diode. This requires the current limiting resistor R29, which is not in the reference schematic.

The analog output is AC coupled to the amplification stage via C12, a very large 470uF capacitor. This prevents the DC difference in LM2917 output for red and blue light from affecting the high gain amplifier stage. Only the pulsating signal component is passed. The output stage of the LM2917 is an emitter follower, which provides a very low output impedance when increasing in output amplitude (NPN proportionally sources more current to the output). However, when switching from red light to blue light, there is a dramatic decrease in output frequency and thus a sudden decrease in the DC output of the LM2917. There is no discharge path for the coupling capacitor which is very large (NPN of emitter follower only sources current, it can’t sink it). The high DC charge on the coupling capacitor prevents the blue light pulse waveforms from reaching the amplification stage. To alleviate this problem, the output of the LM2917 is buffered with a unity gain amplifier (I6). The output impedance of I6 is very low, so C12 has a low time constant even though it is such a large value.

Amplification

The pulsating changes in transmitted light through the patient are very weak, and so the analog signal output of the frequency to voltage stage is also very small in amplitude. Therefore, a high gain amplifier stage is required to provide a waveform suitable for an analog to digital conversion system. Further, the high gain of the circuit requires that it also be immune to environmentally induced noise.

The amplifier circuit has six op-amp stages providing a switchable and adjustable gain range of 200 to 800 or 500 to 2000. The lower range is selected by switching R22 in parallel with R21. To select the higher range, R22 is switched out. To adjust within a selected range, potentiometer I46 can be tweaked for optimal signal output. The overall

pass nature of the circuit has cutoff frequencies of 0.35Hz and 20Hz (see **Frequency Testing, Figure 14, pg. 15**).

The first stage is an instrumentation amplifier stage (I0). The inputs have small shunt resistors (R23, R30) so that the AC coupling capacitor (C12) has a small time constant. I1 is an integration amplifier stage that provides negative feedback to I0 suppressing any DC offsets that could possibly saturate the amplifier block. The following three op-amps (I2, I3, I4) provide additional gain and filtering. The last stage (I5) is a unity gain inverting amplifier which corrects the polarity of the pulsatile waveform.

Switching Glitch Suppression

When switching between red and blue light sensing, the instantaneous change in DC offset of the frequency to voltage converter (I8) induces a 150ms pulse that reaches the high gain amplifier inputs. This glitch throws the amplifier into saturation which takes many seconds to recover from. To eliminate the glitch associated with switching between red and blue light readings, an anti-glitch circuit was developed.

Because the input to the amplifier stage is AC coupled and very low amplitude, the inputs are very near ground. To suppress the switching glitch, the anti-glitch circuit effectively grounds the input to the amplifier stage for the duration of the switching glitch (approximately 150ms). This input grounding is accomplished by driving an NPN transistor (Q0) which is parallel with the amplifier stage input.

The circuitry to drive Q0 has to momentarily respond to both rising and falling edges of the 'pulse' signal that selects red or blue light sensing. Therefore there are two legs to the Q0 driving circuit, one active on rising edges and one active on falling edges.

On the rising edge of 'pulse' Q1 is turned on and drives the base of Q0, pulling the amplifier inputs to low. Q4 is off because its base is also high. The base current of Q1 eventually charges up C0 and turns Q1 off, allowing Q0 to turn off by bleeding any charge at its base through R13. C3 is also discharged on the rising edge of 'pulse.' Diode D0 prevents 'pulse' from instantly charging C0 and preventing Q1 from turning on.

On the falling edge of 'pulse' Q4 is turned on and drives the base of Q0, again pulling the amplifier inputs low. The base current of Q5 eventually charges up C3 and turns off Q5 and Q4, allowing the pulsing signal to reach the amplifier stage input. C0 is also discharged on the falling edge of 'pulse.'

Switching Control

To switch the sensor between red light / low output range and blue light / high output range, a standard LM555 (I9) [17] astable circuit was designed. In order to get an accurate reading from the sensor, it cannot be switched between blue and red light rapidly. The low intensity of the transmitted light results in a low 'DC' frequency output from the

TCS230 light sensor. Therefore our strategy is to measure a few pulses with blue light, and then switch to red for a few pulses. The saturated oxygen content can be calculated based on the average of the previous two reading periods. This approach assumes that the saturated oxygen level in the blood will not change drastically in a few seconds. The switching frequency can be adjusted by choosing the size of capacitor C9. Currently C9 is sized for switching every 5 seconds. This allows an average value to be measured for red light transmission peaks, and then for blue light.

I7 is just a unity gain buffer amplifier for the LM555 output.

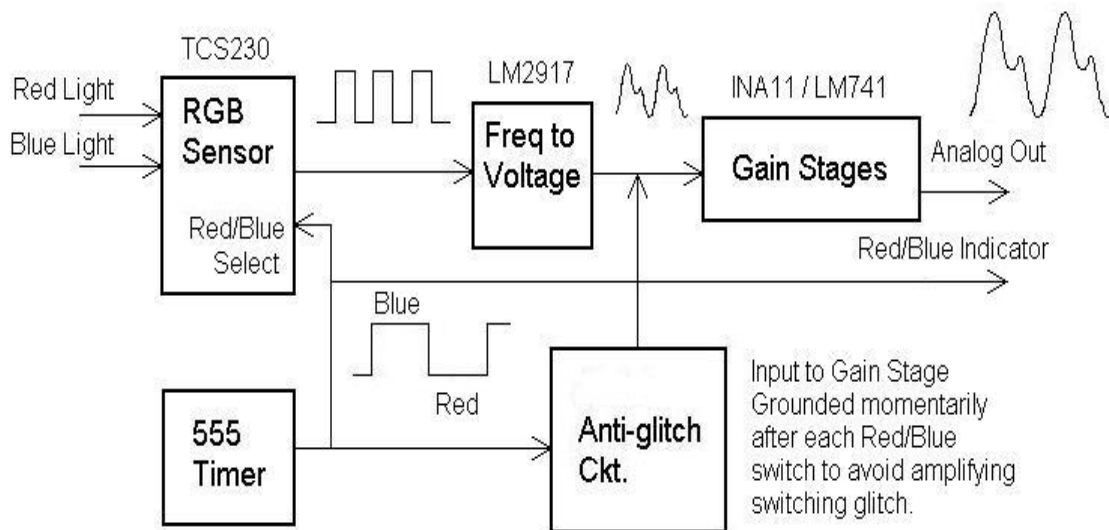

Figure 13 System Block Diagram

Frequency Response of Amplifier Stage

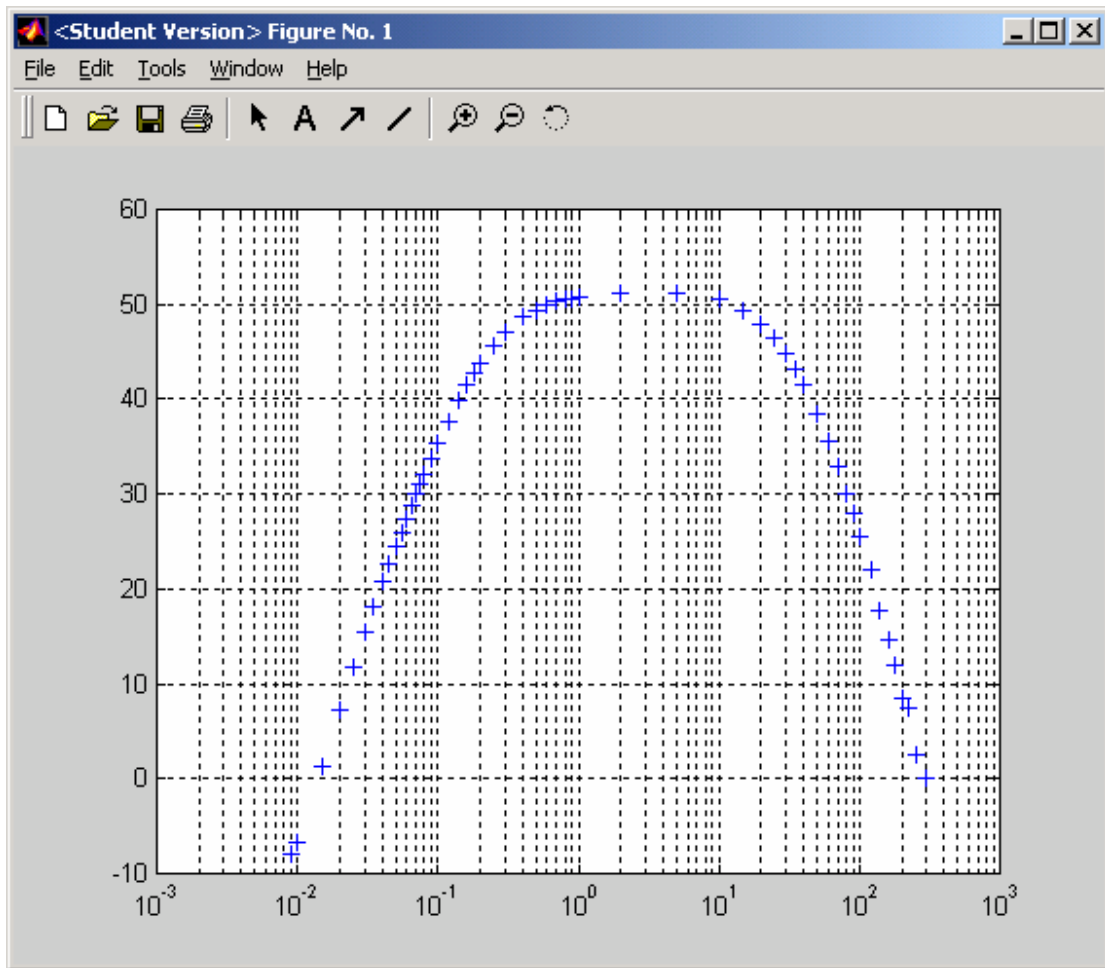

Figure 14 Measured Frequency Response

Data

Freq	input	output	Gain
0.001	0.7	0	0
0.009	0.7	0.28	0.4
0.01	0.7	0.32	0.457143
0.015	0.7	0.82	1.171429
0.02	0.7	1.6	2.285714
0.025	0.7	2.7	3.857143
0.03	0.7	4.1	5.857143
0.035	0.7	5.7	8.142857
0.04	0.7	7.6	10.85714
0.045	0.5	6.7	13.4
0.05	0.5	8.3	16.6

0.055	0.3	6	20
0.06	0.3	7	23.33333
0.065	0.3	8.2	27.33333
0.07	0.2	6.3	31.5
0.075	0.2	7.1	35.5
0.08	0.2	8	40
0.09	0.05	2.4	48
0.1	0.05	2.9	58
0.12	0.05	3.8	76
0.14	0.05	4.9	98
0.16	0.05	5.9	118
0.18	0.05	6.8	136
0.2	0.05	7.8	156
0.25	0.05	9.6	192
0.3	0.05	11.2	224
0.4	0.05	13.5	270
0.5	0.05	14.8	296
0.6	0.05	15.6	312
0.7	0.05	16.3	326
0.8	0.05	16.7	334
0.9	0.05	16.9	338
1	0.05	17.3	346
2	0.05	18	360
5	0.05	18	360
10	0.05	16.7	334
15	0.05	14.5	290
20	0.05	12.3	246
25	0.05	10.4	208
30	0.05	8.7	174
35	0.05	7.2	144
40	0.05	6	120
50	0.05	4.2	84
60	0.05	3	60
70	0.05	2.2	44
80	0.1	3.2	32
90	0.1	2.5	25
100	0.1	1.9	19
120	0.1	1.25	12.5
140	0.3	2.3	7.666667
160	0.3	1.6	5.333333
180	0.3	1.2	4
200	0.3	0.8	2.666667
220	0.3	0.7	2.333333
250	0.3	0.4	1.333333
300	0.3	0.3	1

Testing Procedures

To test sensor selectivity, pure red light was transmitted through a patient and the sensor was measured while switching between blue and red light sensing. The following traces from demonstrate that the sensor is highly selective and effective in discriminating between red and blue light.

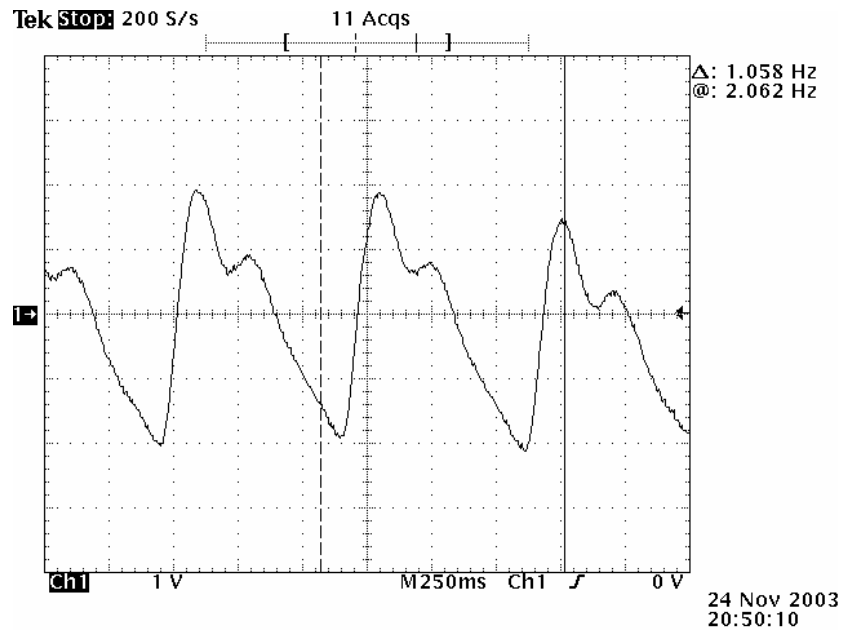

Figure 15 Output for Red light incident, Red sensors selected

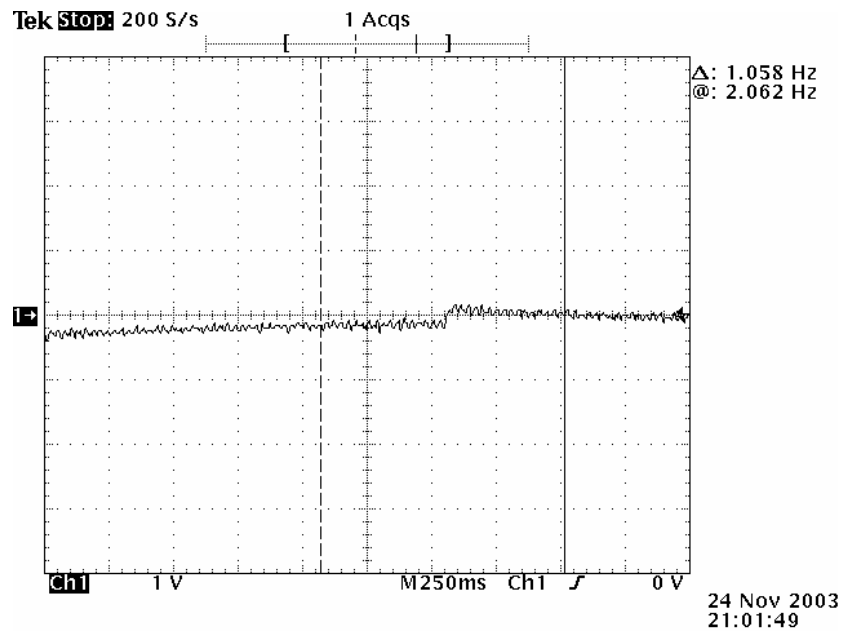

Figure 16 Output for Red light incident, blue sensors selected

The test fixture used to prove our circuit was a finger probe with a blue LED shining through a ruby ball. This setup transmitted both red and blue light through the patient. The sensor was manually switched between red and blue sensitivity and the output was measured using an oscilloscope. The following waveforms (**figures 17 and 18**) demonstrate that both blue and red lights are inducing pulsatile transmission of light through the patient. It can be seen that the output is of higher magnitude for red light as opposed to blue light.

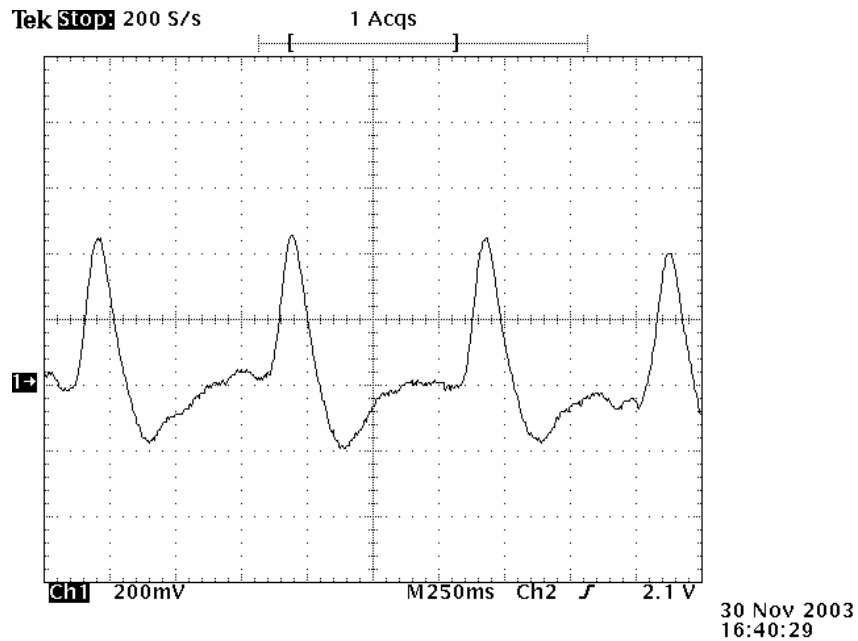

Figure 17 – Blue LED through Ruby, Output with red light sensitivity

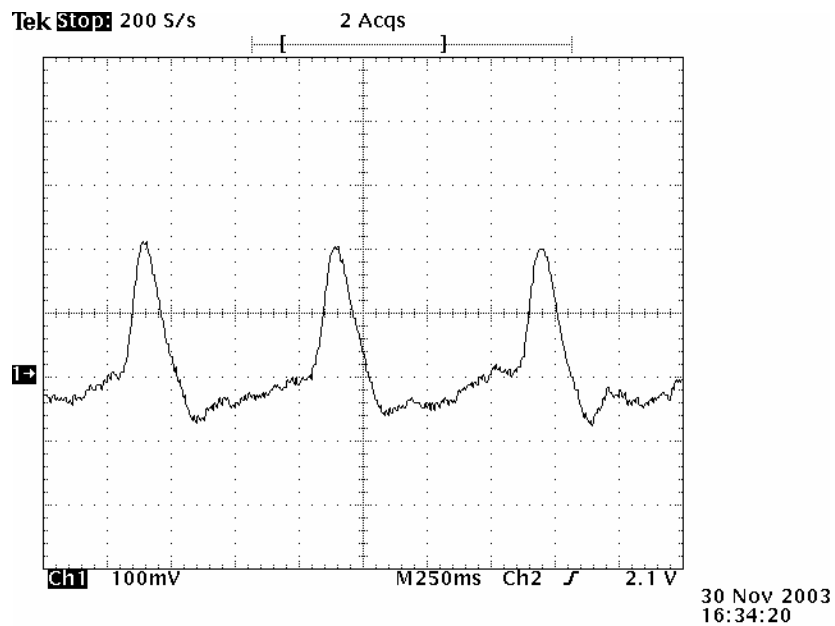

Figure 18 – Blue LED through Ruby, Output with Blue light sensitivity

The effectiveness of the circuit to switching between red and blue light sensitivity was also tested using the blue LED shining through a ruby ball. The ‘pulse’ control signal was switched every 3 seconds. As can be seen in **figure 19**, the output did stabilize, but only after about 1 second of settling time after the switching glitch. This is because the anti-glitch circuitry is not quite fully effective at suppressing the switching glitch. With further optimization of the anti-glitch block, this effect could be minimized.

Also, note that the pulsatile waveform for the red light measurements (control pulse is low) is still twice that of the blue. Assuming an analog to digital converter with sufficient resolution is employed, this disparity in amplitude range should not be a problem. However, if it is, the amount of red light produced relative to blue could possibly be controlled with the thickness of the ruby layer on the LED substrate.

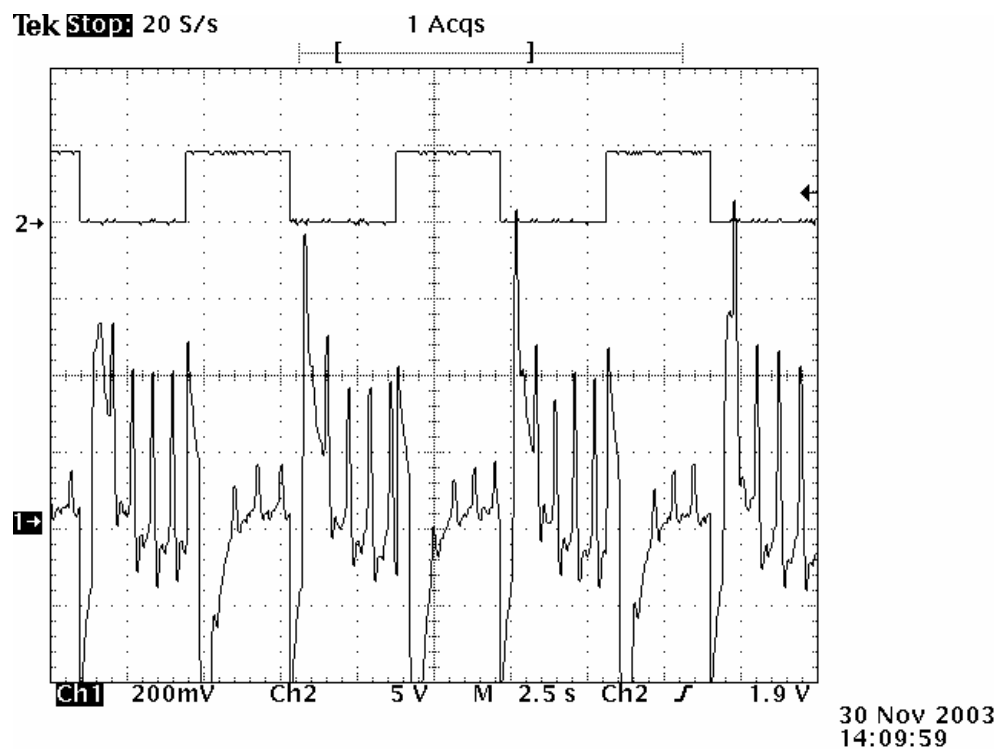

Figure 19 Output measured when switching between red and blue sensitivity

Conclusions

- It is possible to use a blue LED and a Ruby to implement transmission oximetry.
- Using a blue LED and a Ruby saves on the additional circuitry needed to calibrate the light intensity from different light sources.
- The transmission rate of blue light through blood can be detected using a highly sensitive color sensor.

Acknowledgments

We would like to acknowledge Dr. John Muth, Assistant Professor of Electrical and Computer Engineering North Carolina State University for guiding us towards the application of blue LED's and rubies in the application of pulse oximetry.

References

- [1] <http://www.people.virginia.edu/~rjh9u/oxytrans.html>
- [2] http://www.ninds.nih.gov/health_and_medical/disorders/anoxia_doc.htm
- [3] <http://www.vision.net.au/~apaterson/science/hypoxia.htm>
- [4] <http://www.flightstat.nonin.com/hypoxia.pdf>
- [5] <http://www.svda.info/emacs/anemerg/hypoxia.html>
- [6] <http://www.oximeter.org>
- [7] Medical Instrumentation: Application and Design Edited by John Webster. John Wiley and Sons, 1998. Chapter 10: page 453, 470-472.
- [8] http://courses.ncsu.edu/ece525/common/media/10/Chapter10_files/frame.htm
- [9] <http://www.mountainflying.com/oxygen.htm>
- [10] <http://server1.bme.ufl.edu/classes/instrumentation/pulseox.pdf>
- [11] http://www.med.nus.edu.sg/paed/medical_education/cardiac_thumbnail/investigations/oximetry.htm
- [12] <http://www.nirsoptix.com/historical.htm>
- [13] Andrew Oberhofer, John Muth *et al.*, *Integrated Optical Pumping of Ruby Substrates by InGaN LED Grown on Cr:Sapphire*, Materials Research Society Meeting, 2003.
- [14] USB2000 Manual, <http://www.oceanoptics.com/products/usb2000.asp>.
- [15] <http://www.superbrightleds.com/leds.htm>
- [16] <http://cache.national.com/ds/LM/LM2907.pdf>
- [17] Mims, Forrest M. Engineer's Mini-Notebook. 555 Timer IC Circuits. Silicon Concepts, Fort Worth, TX. 1984.
- [18] Schmitt, J. 1991. Simple Photon Diffusion Analysis of the Effects of Multiple Scattering on Pulse Oximetry. IEEE Trans on Biomed Engin 1194–1203.
- [19] Salyer J. 2003. Neonatal and Pediatric Pulse Oximetry. Respiratory Care 386–398.
- [20] <http://www.taosinc.com/images/product/document/TCS230.pdf>